

ATEX geprüfte Feststoff-Ausführung
ATEX approved valve for bulk material

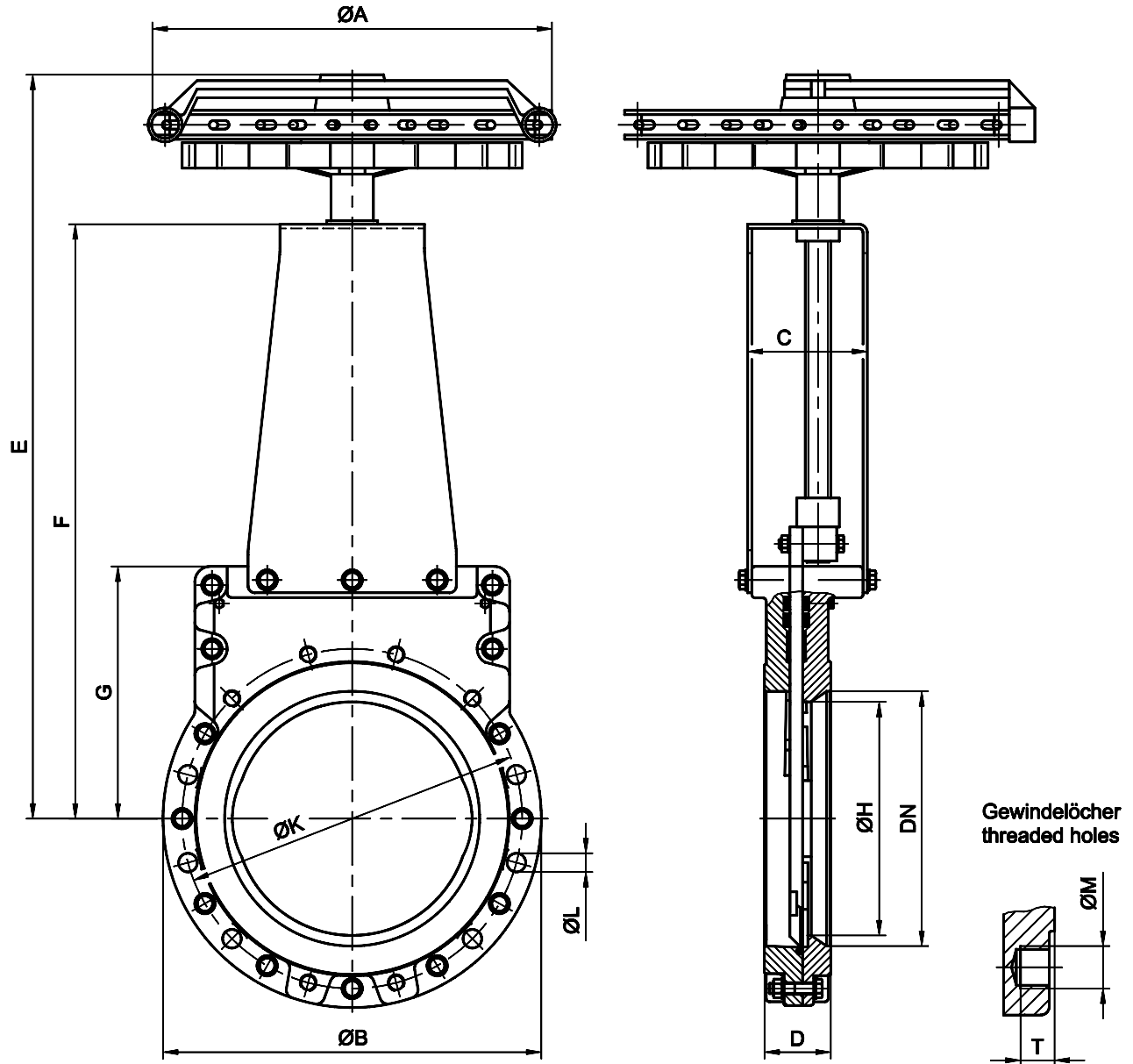

DN	NPS	Kettenrad Chain wheel Typ / type	ØA	ØB	C	D	E	F	G	ØH	ØK	ØL	ØM	T	kg
200	8"	CW 2,5	305	340	104	60	652	508	220	178	295	4xØ22	4xM20	16	41
250	10"	CW 3	380	395	141	68	821	660	257	222	350	6xØ22	6xM20	18	63
300	12"	CW 3,5	470	445	141	78	874	700	297	275	400	6xØ22	6xM20	18	85

Max. Betriebsdruck / max. working pressure: 10 bar

Änderungen vorbehalten
 subject to changes